



**DIRECTIONAL LEDs**

Beacons | Lightbars | Minibars | Worklamps | Back-Up Alarms | Camera Systems

## 3735 SERIES Surface Mount

This compact and versatile surface-mount LED directional light is ideal for applications requiring high intensity output, low-current draw and maintenance-free operation. These auxiliary LED heads feature a clear acrylic lens optic with LEDs that illuminate in the color of your choice. Warning capability can be customized by selecting from 11 different flash patterns (via a trigger wire).

### Models

PART NO.	VOLTAGE	AMPS	MOUNT
3735X	12	0.3	Surface

Replace X in part number with desired color: A=amber, B=blue, C=clear, G=green, R=red

### Features and Benefits

- ABS plastic housing with encapsulated electronics
- 11 flash patterns
- Discrete units are colorless when not illuminated
- LEDs offer a long, maintenance-free service life
- CE, R10, IP67
- Temperature Range: -22°F to +122°F (-30°C to +50°C)
- Warranty: 1 year

### Accessories

UNIVERSAL  
A3730BKT



TRUNK  
A3730TNK



DECK  
A3730DCK



WINDOW  
A3730WIN



LICENSE  
A3730LIC

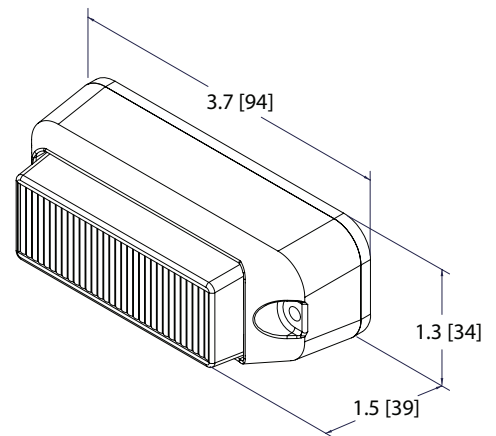

### Flash Patterns (11)

- Steady Burn
- Single
- Fast Single
- Double
- Fast Double
- Triple
- Quad
- Quint Hold
- Pulse8
- Constant Pulse8
- Cycle