

## Installation Manual

### L.MAS.MOV.C.M

Nissan Interstar, 1999 - 2010  
Opel Movano, 1999 - 2010  
Renault Mastervan, 1999 - 2010





Nissan Interstar

Opel Movano

Renault Mastervan

## L.MAS.MOV.C.M

### CONTENTS

1. FOREWORD .....	3
2. INTRODUCTION .....	4
3. VERY IMPORTANT NOTES.....	5
4. COMPLETE ASSEMBLY .....	7
5. INSTRUCTIONS FOR INSTALLATION .....	8
5.1. Preliminary Step—LSV Spring Length Measurement .....	8
5.2. Bump Stop Removal and Fitting of Upper Plate.....	8
5.3. Fitting of Lower Bracket .....	9
5.4. Bellow Installation.....	9
5.5. Fitting of Inflator Console.....	10
5.6. Tube Connection and Disconnection, Cutting and Routing .....	11
5.7. Spring Inflation.....	12
5.8. Spring Alignment .....	13
5.9. <b>IMPORTANT!</b> Load Sensing Valve (LSV) Adjustment .....	13
5.10. Maintenance.....	13
5.11. Installation Drawings .....	14
6. EPILOGUE .....	17

DSC Nederland B.V.  
Het Wegdam 22  
7496 CA Hengevelde  
Nederland  
Tel. : +31 (0)547 333065  
Fax. : +31 (0)547 333068  
e-mail: [info@dunlopsystems.nl](mailto:info@dunlopsystems.nl)  
Website: [www.dunlopsystems.nl](http://www.dunlopsystems.nl)

© 2017, DSC Nederland B.V.



Nissan Interstar

Opel Movano

Renault Mastervan

## L.MAS.MOV.C.M

### 1. FOREWORD

This manual provides instructions for the installation of an auxiliary air suspension kit, developed specifically for the Nissan Interstar, Opel Movano and Renault Mastervan. To ensure correct installation of the kit, it is strongly recommend that these instructions are read thoroughly before commencing any installation work. Installation should only be carried out by a suitably qualified mechanic or specialist installation facility. DSC Nederland will not accept any responsibility for faults or defects arising from incorrect installation, which automatically renders the guarantee invalid.

#### **IMPORTANT : Manufacturer's Declaration Form**

**A manufacturer's declaration form is provided with your kit. Following installation of the kit please ensure that this form is completed, signed by a qualified fitter and a copy is returned to DSC Nederland by post, fax or e-mail. Our e-mail address is: [info@dunlopsystems.nl](mailto:info@dunlopsystems.nl)**

This kit is suitable for motorhomes and other vehicles with a minimum rear axle load of 1350kg (2975lbs).



Nissan Interstar

Opel Movano

Renault Mastervan

## L.MAS.MOV.C.M

### 2. INTRODUCTION

Thank you for choosing an auxiliary air suspension kit from the range offered by *DSC Nederland*. Auxiliary air suspension is fitted in tandem with the standard steel springs of the vehicle suspension, and provides enhancements in terms of both the stability of the vehicle and the comfort of the passengers...

#### **Vehicle Levelling**

Simply by varying the air pressure in the springs, the vehicle can be levelled both front-to-rear and side-to-side. Keeping the vehicle level optimises stability, ensures correct headlamp beam distribution and reduces tyre wear arising from uneven distribution of weight.

#### **Straight Line Stability**

Straight line stability is greatly increased at higher speeds, and when subjected to buffeting from cross-winds or large overtaking vehicles

#### **Reduced Body Roll**

Body roll when cornering or negotiating roundabouts is significantly reduced.

#### **Fatigue Reduction and Wear Compensation**

Suspension fatigue is reduced, so helping to prevent leaf springs from sagging under repeated or constant loading. Any sagging already present can be compensated-for. This is a particular benefit for motorhomes, which are always fully laden.

#### **Ride Comfort**

Air springs help to absorb shock loads from uneven road surfaces, therefore general ride quality is much improved.

### 3. VERY IMPORTANT NOTES



#### **Gross Vehicle Weight (GVW)**

**Air assist kits are not in themselves designed to increase the gross vehicle weight (GVW) rating of a vehicle.** They do not legally allow for carriage of a load greater than the carrying capacity stated on the data plate of the vehicle.

Do not exceed the maximum load specified by the vehicle manufacturer...

- ◆ to avoid compromising passenger safety
- ◆ to prevent possible damage to the vehicle
- ◆ for legal reasons



#### **Load Sensing Valve (LSV) Adjustment**

If your vehicle is not fitted with an antilock braking system (ABS) then it will have a load sensing valve (LSV) to automatically adjust braking force under varying load conditions. This valve **must** be adjusted immediately after the fitting of an air assist kit and before the vehicle is driven again on public roads.

If the LSV is not adjusted following the fitting of an air assist kit, it may misjudge rear load conditions to the extent that the braking pressure applied to the rear brakes is not correct (e.g. the rear wheels may lock with no load on the rear axle). The consequences of this in terms of vehicle stability and safety are potentially serious.

### **Vehicle Upgrading**

Despite the above words of caution, it is possible to upgrade the weight rating of your vehicle. This must be carried-out by a specialist supplier that will...

- ◆ carry out any necessary modifications in addition to fitting the air assist kit
- ◆ complete documentation as necessary to inform the Vehicle and Operator Services Agency (VOSA) – a mandatory requirement
- ◆ supply and fit a new weight plate to replace the original plate supplied with the vehicle

This process applies to United Kingdom registered vehicles. The process in other countries may be different.



Nissan Interstar

Opel Movano

Renault Mastervan

## L.MAS.MOV.C.M

### Safety Guidance Note

The following very useful guidance note is available for free download from the *Health and Safety Executive (HSE)*...

**PM85, July 2007** *Safe recovery (and repair) of buses and coaches fitted with air suspension*

The uniform resource locator (URL) for this document is...

<http://www.hse.gov.uk/PUBNS/pm85.pdf>

#### 4. COMPLETE ASSEMBLY

The complete bellow and bracket assembly is shown by the diagram below...

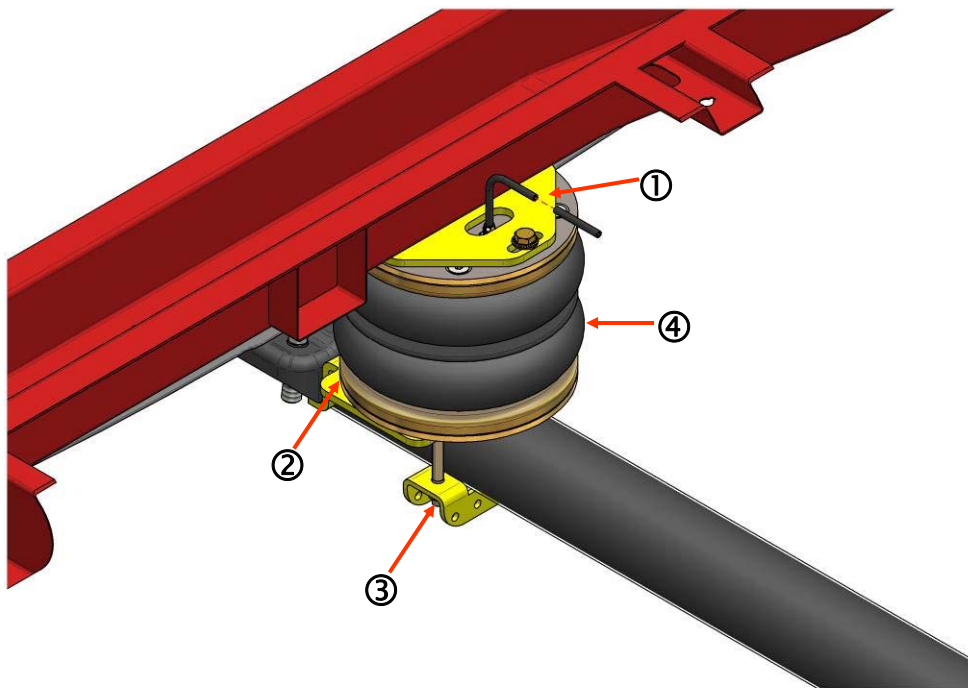

No.	Part
①	Upper Plate
②	Lower Bracket
③	Lower Bracket Strap
④	Air Bellow 170/2



Nissan Interstar

Opel Movano

Renault Mastervan

## L.MAS.MOV.C.M

### 5. INSTRUCTIONS FOR INSTALLATION



#### Preparation and Precaution

Before beginning installation, ensure that you have sufficient clearance between the axle and the chassis. Use a jack if necessary. Install at one side of the vehicle at a time.



Pay attention to your safety at all times during installation - always use axle stands to support the vehicle!



The following instructions make reference to the diagrams on pages 16 and 17.

#### 5.1 Preliminary Step - LSV Spring Length Measurement

Vehicles without an antilock braking system have a load sensing valve fitted. This has a spring linkage as shown by Figure 1. Before beginning installation, measure and record the length (x) of the linkage between the chassis and the axle mounting brackets.

#### 5.2 Bump Stop Removal and Fitting of Upper Plate

- i. Unscrew and remove the bump stop—Figures 2 and 3. The two holes vacated by removal of the bump stop will be used for attachment of the upper plate.
- ii. Position the plate underneath the two holes in the chassis rail (left by removal of the bump stop) such that it protrudes towards the centre of the vehicle. Attach the plate using two countersunk screws—Figures 4 and 5.





Nissan Interstar

Opel Movano

Renault Mastervan

## L.MAS.MOV.C.M

### 5.3 Fitting of Lower Bracket

- i. Rest the lower bracket on the axle directly below the upper plate, with the two 'feet' placed beneath the leaf spring mounting block—Figure 6
- ii. Insert the two M10 x 100mm countersunk bolts into the countersunk holes in the lower bracket, feed the lower bracket strap up from below the axle to mate with these bolts, and install the nuts and washers to secure the lower bracket and strap against the axle—Figures 6 and 7

### 5.4 Bellow Installation

- i. See Section 5.6 - "*Tube Connection and Disconnection, Cutting and Routing*" : Connect a tube to the bellow by pushing the tube into the air inlet port on the underside of the spring and then hand-rotating the tube by one screw turn. Use black tubing for the left-hand bellow and blue for the right-hand bellow. Feed the tube through the large exposed hole in the upper bracket—Figure 8.
- ii. Place the bellow into position between the upper and lower brackets and attach the lower plate of the bellow to the lower bracket using two M8 x 16mm bolts and two washers—Figures 8 and 9
- iii. Attach the top plate to the top plate of the bellow using a single M8 x 20mm bolt and a single M8 serrated washer—Figures 10 and 11

Nissan Interstar

Opel Movano

Renault Mastervan

## L.MAS.MOV.C.M

### 5.5 Fitting of Inflator Console

Option Valves



Option 1

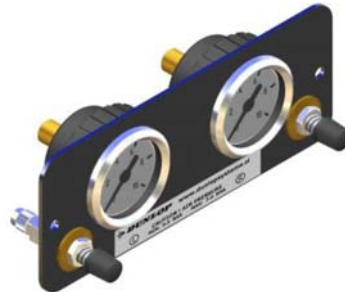

Option 2



Option 3



Your kit is supplied with one of the inflator options console shown above...

- 'Option Valves', having two valves and a bracket (above, top-left)
- 'Option 1', 'Option 2' or 'Option 3', having both valves and pressure gauges

Mount the console in a position of your choice whereby it is firmly fixed, has some protection from the environment (particularly important for the console with gauges) and is easily accessible. Suggested possible locations include...

#### Console with Valves Only...

- on the rear bumper
- at the rear beside the license plate
- on the chassis next to a rear wheel
- in a service shutter
- beside the fuel cap

#### Console with Valves and Gauges...

- in the vehicle cabin, within reach and sight of the driver
- in the wall of a cupboard (motorhomes)
- in a service shutter

#### 'Comfort' Packages

The 'Option 2' and 'Option 3' panels, as shown above, are each part of a *Comfort Package* that is supplied with a compressor (and also an air reservoir in the case of the 'Option 3' panel) for ease of spring inflation and ride height setting. For further information please ask your dealer.

## 5.6 Tube Connection and Disconnection, Cutting and Routing

### Connection and Disconnection

Tubes are connected as shown by the diagrams below...

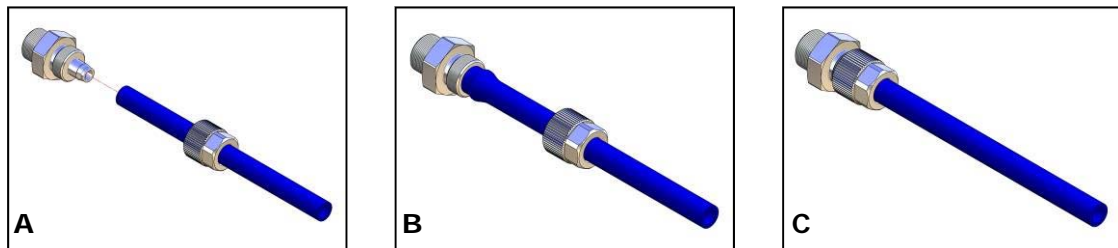

- A. Slide a nut over the end of the tube
- B. Push the tube onto the connector as far as possible
- C. Feed the nut up to the connector, fully tighten by hand and finally tighten one additional turn using spanners

### Cutting

To achieve good sealing and air-tight fitting of tube ends to their connecting parts, it is very important to cut tubing cleanly and squarely. A dedicated guillotine action tubing cutter is recommended, or a craft knife if such a tool is not available. Do not use electrician's side cutters.



A dedicated tubing cutter -  
**Recommended**



Electrician's Side Cutters  
**NOT Recommended**



Nissan Interstar

Opel Movano

Renault Mastervan

## L.MAS.MOV.C.M

### Routing

Study the underside of the vehicle and decide how to route each branch of the air circuit...

- To minimise the risk of chafing, avoid running tubing over metal edges as much as possible
- Avoid close proximity to heat sources such as the exhaust assembly
- Choose a route that provides as much protection as possible from dirt, debris and any solid objects that may impact the underside of the vehicle

It is recommended that tubes are guided alongside brake lines as much as possible.



Use cable ties ('tie wraps') to secure tubing to the chassis, taking care not to over-tighten them.

### 5.7 Spring Inflation

Once installation of the air assist kit is complete, inflate the springs via the inflator console taking careful note of the following...



#### Maximum and Minimum Pressure

**Maximum Pressure 7.0bar**

**Minimum Pressure 0.5bar**

Do not exceed 7.0bar (101psi), which is the recommended maximum charge pressure for the air springs.

The springs may be deflated if the vehicle is to be stored for a lengthy period without use, but a pressure of at least 0.5bar (7.25psi) should be maintained at all times in order to avoid possible compression damage to the springs.

Nissan Interstar

Opel Movano

Renault Mastervan

## L.MAS.MOV.C.M

### 5.8 Spring Alignment

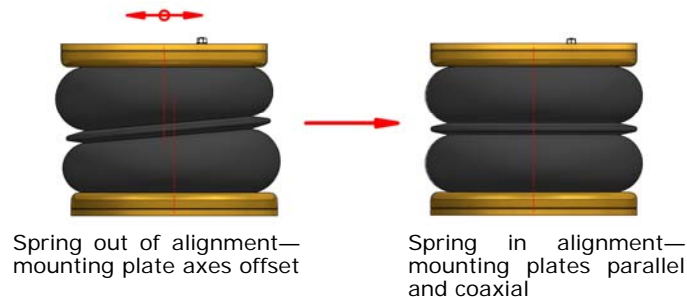

#### CAUTION!

Before fully tightening the bolts that secure the air spring to the upper and lower brackets, set the vehicle at ride height (spring height approximately 14cm) and ensure that the springs are correctly aligned.

### 5.9 **IMPORTANT!** Load Sensing Valve (LSV) Adjustment

Once the auxiliary air suspension system is installed and the bellows are inflated such that the desired vehicle ride height is achieved, the LSV must be adjusted—see Figure 13. Inflate the springs to a height of 13.5cm, then adjust the length of the spring linkage via the adjustment collar until the total length between the chassis and axle mounting brackets is the same as it was before beginning installation (see 'Preliminary Step', Section 5.1).

The adjustment collar has a screw that locks the outer part of the linkage to the inner part when tightened and enables the inner part to slide inside the outer part when loosened.

### 5.10 Maintenance

Following installation, it is recommended that all metal parts are coated with a protective substance such as body wax.

The system does not require very much maintenance other than...

- ◆ to maintain air pressure in the springs. Much like a tyre, the system may lose a little air over time.
- ◆ to keep the air bellows clean. It is suggested that, when washing the vehicle, the bellows are inspected and cleaned as necessary (preferably by spraying). Look in particular for stones or grit trapped between convolutes, as this may damage the bellow.



Nissan Interstar

Opel Movano

Renault Mastervan

**L.MAS.MOV.C.M**

## 5.11 Installation Drawings

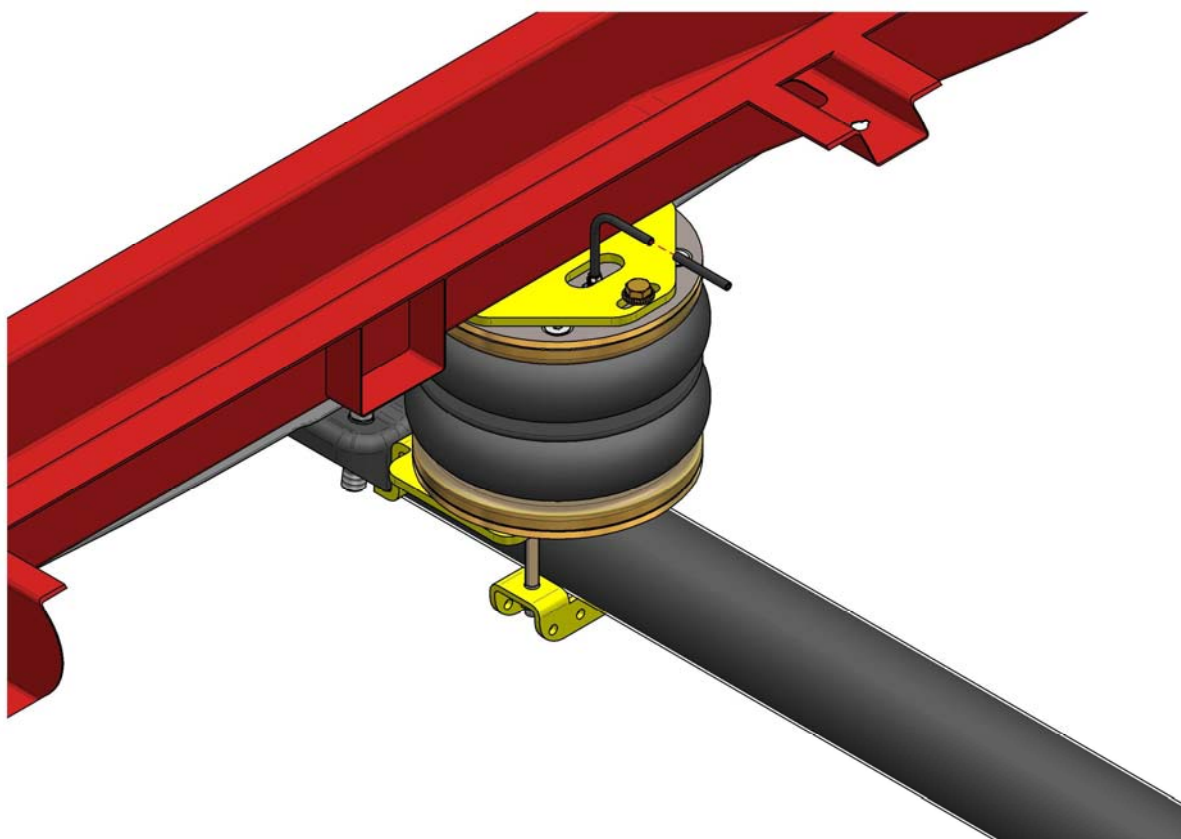



Nissan Interstar

Opel Movano

Renault Mastervan

**L.MAS.MOV.C.M**

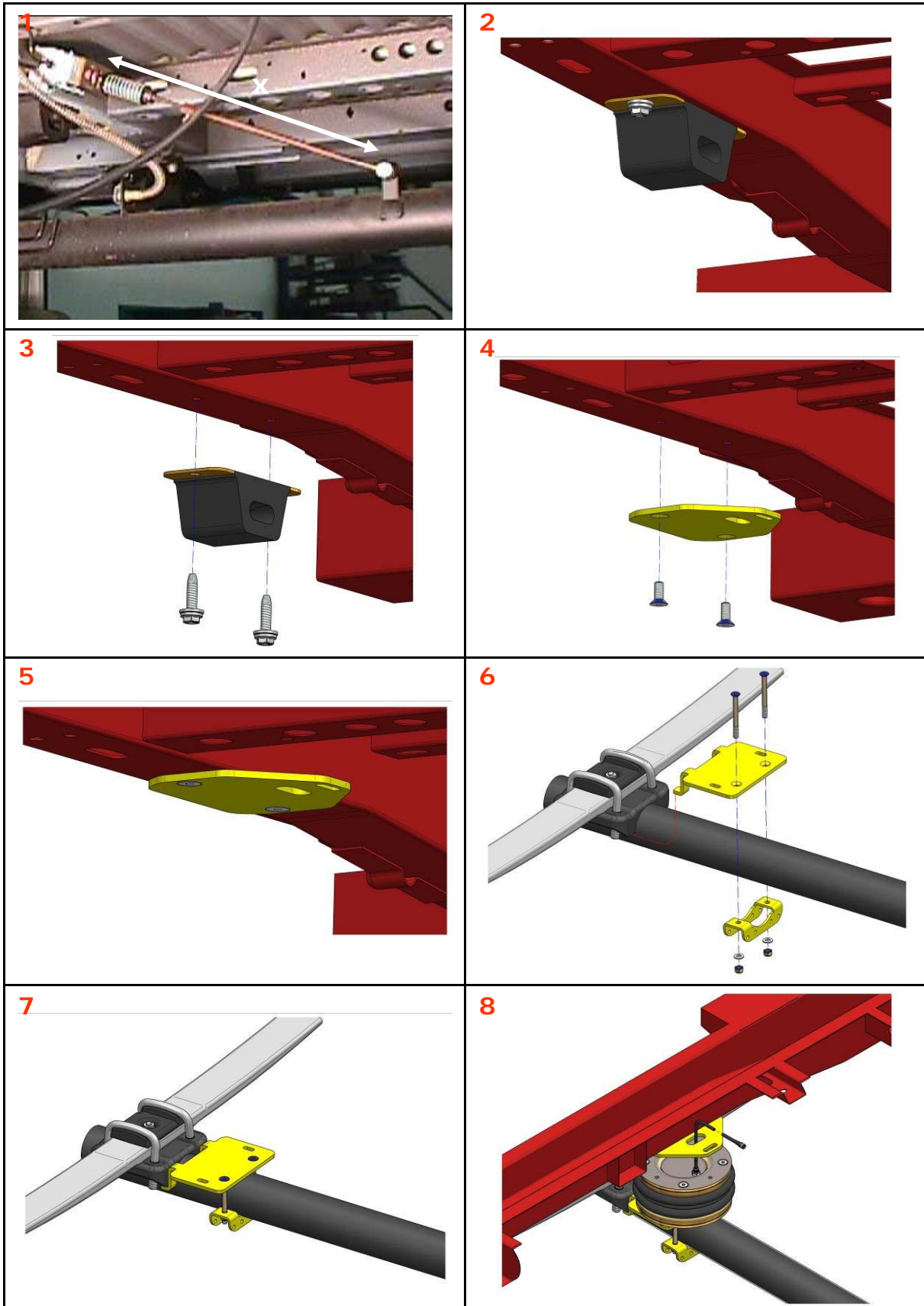

Nissan Interstar

Opel Movano

Renault Mastervan

**L.MAS.MOV.C.M**

<p><b>9</b></p>	<p><b>10</b></p>
<p><b>11</b></p>	<p><b>12</b></p> <p>Spring out of alignment—mounting plate axes offset      Spring in alignment—mounting plates parallel and coaxial</p> <p><b>CAUTION!</b> Before fully tightening the bolts that secure the air spring to the upper and lower brackets, set the vehicle at ride height (spring height approximately 13.5cm) and ensure that the springs are correctly aligned.</p>
<p><b>13</b></p>	





Nissan Interstar

Opel Movano

Renault Mastervan

## L.MAS.MOV.C.M

### 6. EPILOGUE

DSC Nederland hopes that you enjoy the benefits that your *DUNLOP* air suspension system will provide for you. To ensure optimal performance, we advise that you have your system checked frequently by qualified personnel. As recommended in the fitting instructions, it is important to coat all the steel parts with a protective substance such as body wax.

#### **IMPORTANT : Manufacturer's Declaration Form**

**A manufacturer's declaration form is provided with your kit. Following installation of the kit please ensure that this form is completed, signed by a qualified fitter and a copy is returned to DSC Nederland by post, fax or e-mail. Our e-mail address is: [info@dunlopsystems.nl](mailto:info@dunlopsystems.nl)**

As a condition of your warranty, modifications to the system may only be carried out by personnel of DSC Nederland.

#### **Enquiries**

For general enquiries please contact one of our dealers. You can find them on our website.

[www.dunlopsystems.nl](http://www.dunlopsystems.nl)

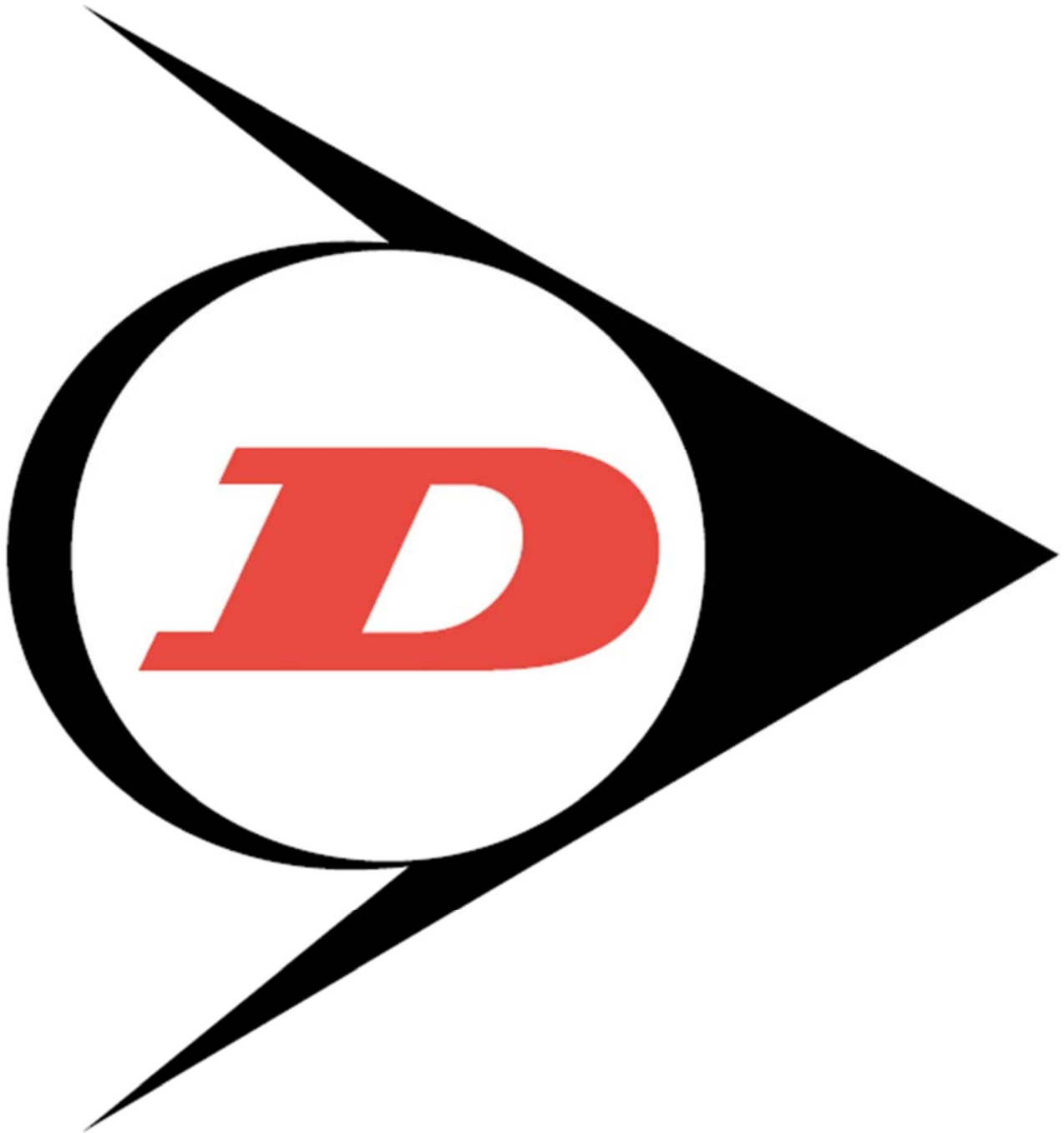

DSC Nederland B.V.  
Het Wegdam 22  
7496 CA Hengevelde  
Nederland  
Tel. : +31 (0)547 333065  
Fax. : +31 (0)547 333068  
e-mail: [info@dunlopsystems.nl](mailto:info@dunlopsystems.nl)

[www.dunlopsystems.nl](http://www.dunlopsystems.nl)