

# Installation Manual

## L.HI.L4.C.M

### Toyota Hilux 4WD 1998 - 2015

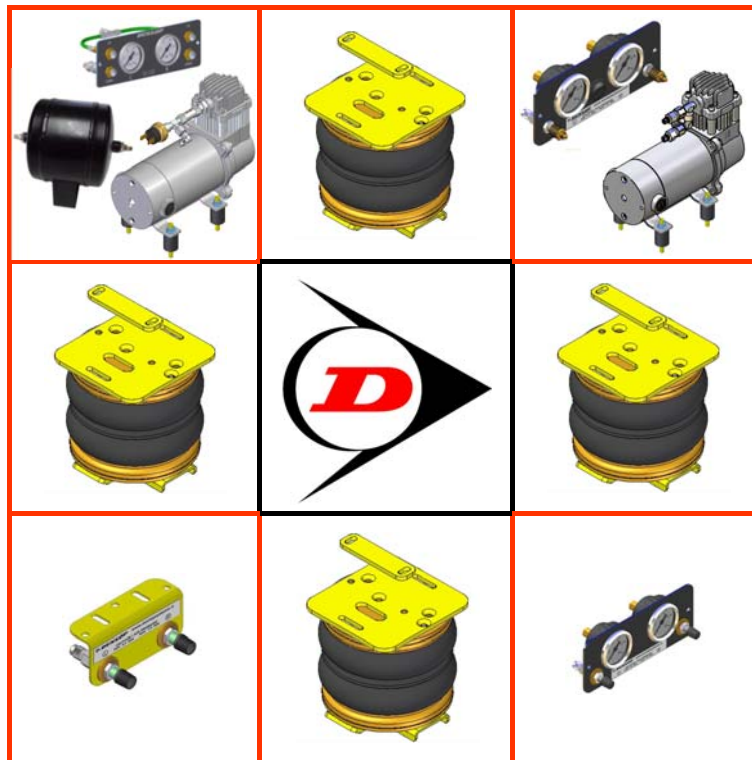



Toyota Hilux 4WD  
L.HI.L4.C.M

CONTENTS

1. FOREWORD .....	3
2. INTRODUCTION .....	4
3. VERY IMPORTANT NOTES.....	5
4. EXPLODED VIEW .....	7
5. INSTRUCTIONS FOR INSTALLATION .....	8
5.1. Attaching the top plate to the chassis .....	8
5.2. Installing of the lower plate .....	9
5.3. Installing of the air spring .....	9
5.4. Fitting of Inflator Console.....	10
5.5. Tube Connection and Disconnection, Cutting and Routing .....	12
5.6. Spring Inflation.....	13
5.7. Spring Alignment .....	14
5.8. Maintenance.....	14
5.9. Installation pictures.....	15
5.10. Check List .....	17
6. EPILOGUE .....	17

DSC Nederland B.V.  
Het Wegdam 22  
7496 CA Hengevelde  
Nederland  
Tel. : +31 (0)547 333065  
Fax. : +31 (0)547 333068  
e-mail: [info@dunlopsystems.nl](mailto:info@dunlopsystems.nl)  
Website: [www.dunlopsystems.nl](http://www.dunlopsystems.nl)

© 2017, DSC Nederland B.V.



## Toyota Hilux 4WD L.HI.L4.C.M

### 1. FOREWORD

This manual provides instructions for the installation of an auxiliary air suspension kit, developed specifically for the Iveco Daily 60C and 65C (1999—onwards). To ensure correct installation of the kit, it is strongly recommend that these instructions are read thoroughly before commencing any installation work. Installation should only be carried out by a suitably qualified mechanic or specialist installation facility. DSC Nederland will not accept any responsibility for faults or defects arising from incorrect installation, which automatically renders the guarantee invalid.

#### **IMPORTANT : Manufacturer's Declaration Form**

A manufacturer's declaration form is provided with your kit. Following installation of the kit please ensure that this form is completed, signed by a qualified fitter and a copy is returned to DSC Nederland by post, fax or e-mail. Our e-mail address is: [info@dunlopsystems.nl](mailto:info@dunlopsystems.nl)



## Toyota Hilux 4WD L.HI.L4.C.M

### 2. INTRODUCTION

Thank you for choosing an auxiliary air suspension kit from the range offered by *DSC Nederland* Auxiliary air suspension is fitted in tandem with the standard steel springs of the vehicle suspension, and provides enhancements in terms of both the stability of the vehicle and the comfort of the passengers...

#### **Vehicle Levelling**

Simply by varying the air pressure in the springs, the vehicle can be levelled both front-to-rear and side-to-side. Keeping the vehicle level optimises stability, ensures correct headlamp beam distribution and reduces tyre wear arising from uneven distribution of weight.

#### **Straight Line Stability**

Straight line stability is greatly increased at higher speeds, and when subjected to buffeting from cross-winds or large overtaking vehicles.

#### **Reduced Body Roll**

Body roll when cornering or negotiating roundabouts is significantly reduced.

#### **Fatigue Reduction and Wear Compensation**

Suspension fatigue is reduced, so helping to prevent leaf springs from sagging under repeated or constant loading. Any sagging already present can be compensated-for. This is a particular benefit for motorhomes, which are always fully laden.

#### **Ride Comfort**

Air springs help to absorb shock loads from uneven road surfaces, therefore general ride quality is much improved.

Toyota Hilux 4WD  
L.HI.L4.C.M

### 3. VERY IMPORTANT NOTES



#### Gross Vehicle Weight (GVW)

Air assist kits are not in themselves designed to increase the gross vehicle weight (GVW) rating of a vehicle. They do not legally allow for carriage of a load greater than the carrying capacity stated on the data plate of the vehicle.

Do not exceed the maximum load specified by the vehicle manufacturer...

- ◆ to avoid compromising passenger safety
- ◆ to prevent possible damage to the vehicle
- ◆ for legal reasons



#### Load Sensing Valve (LSV) Adjustment

If your vehicle is not fitted with an antilock braking system (ABS) then it will have a load sensing valve (LSV) to automatically adjust braking force under varying load conditions. This valve **must** be adjusted immediately after the fitting of an air assist kit and before the vehicle is driven again on public roads.

If the LSV is not adjusted following the fitting of an air assist kit, it may misjudge rear load conditions to the extent that the braking pressure applied to the rear brakes is not correct (e.g. the rear wheels may lock with no load on the rear axle). The consequences of this in terms of vehicle stability and safety are potentially serious.

#### Vehicle Upgrading

Despite the above words of caution, it is possible to upgrade the weight rating of your vehicle. This must be carried-out by a specialist supplier that will...

- ◆ carry out any necessary modifications in addition to fitting the air assist kit
- ◆ complete documentation as necessary to inform the Vehicle and Operator Services Agency (VOSA) – a mandatory requirement
- ◆ supply and fit a new weight plate to replace the original plate supplied with the vehicle

This process applies to United Kingdom registered vehicles. The process in other countries may be different.



## Toyota Hilux 4WD L.HI.L4.C.M

### Safety Guidance Note

The following very useful guidance note is available for free download from the *Health and Safety Executive* (HSE)...

**PM85, July 2007** *Safe recovery (and repair) of buses and coaches fitted with air suspension*

The uniform resource locator (URL) for this document is...

<http://www.hse.gov.uk/PUBNS/pm85.pdf>

Toyota Hilux 4WD  
L.HI.L4.C.M

4. EXPLODED VIEW

The complete exploded view is shown by the diagram below...

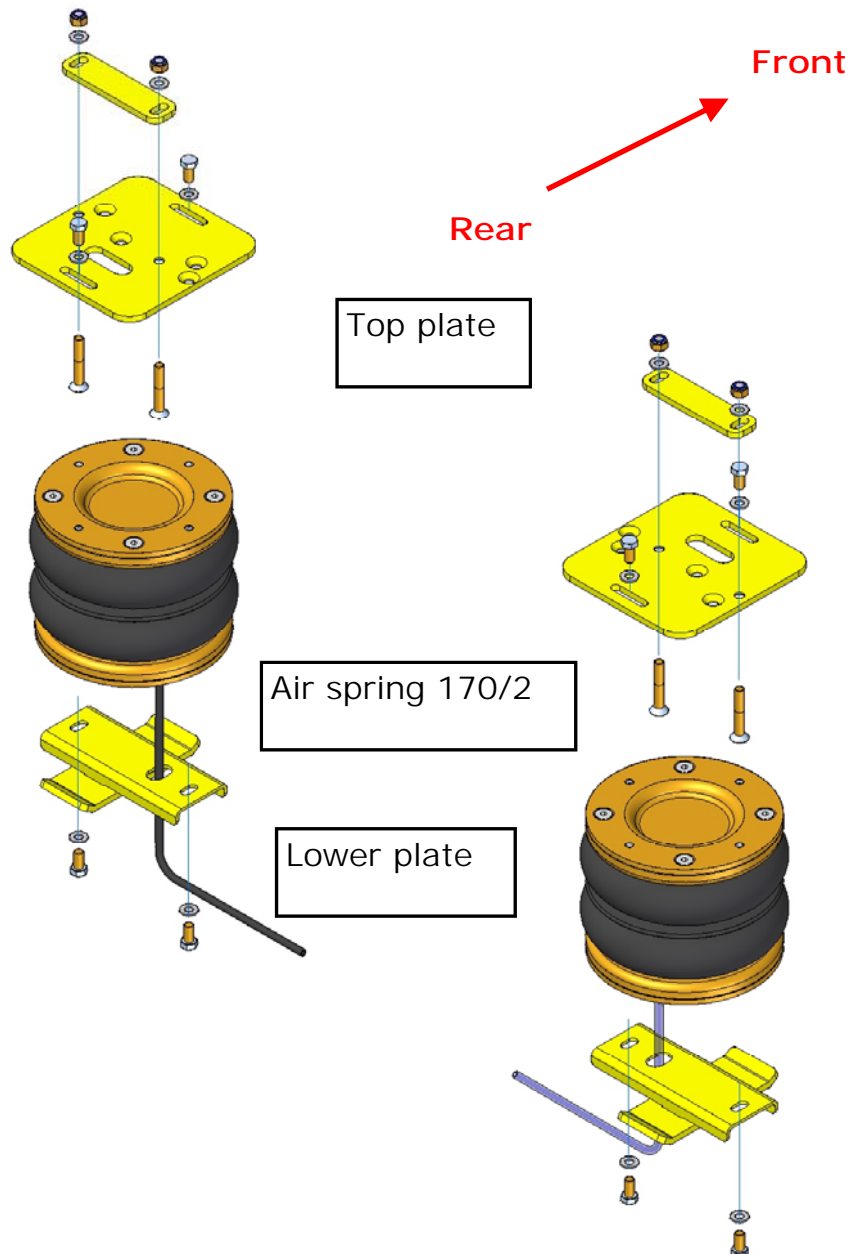

In addition to the parts illustrated above, the kit comprises of...

- either a two-valve inflator console or (optionally) a console with pressure gauges
- cable Ties
- a Manufacturer's Declaration form
- installation Instructions

Toyota Hilux 4WD  
L.HI.L4.C.M

**5. INSTRUCTIONS FOR INSTALLATION**



**Preparation and Precaution**

Before beginning installation, ensure that you have sufficient clearance between the axle and the chassis. Use a jack if necessary. Install at one side of the vehicle at a time.



Pay attention to your safety at all times during installation - always use axle stands to support the vehicle!



Position the axle stands under the chassis (not the rear axle) with a clearance of approximately 25 cm between the chassis and the rear axle.

**Recommended Tightening Torque**

During fitting of the air suspension system, it is recommended that nuts and bolts are tightened in accordance with the following table...

METRIC TORQUE CHART IN N.m		
SIZE	CLASS 8.8	CLASS 10.9
M6 x 1	9.9	14.0
M8 x 1.25	24.0	34.0
M10 x 1.5	48.0	67.0
M12 x 1.75	83.0	117.0
M16 x 2	200.0	285.0

- When both the bolt and nut are made from steel use either class 8.8 or 10.9
- For all other materials, tightening torque is left to the discretion of a person skilled in the art

The following instructions make reference to the diagrams on page 15.

**5.1 Attaching the top plate to the chassis**

1. Check if the strap fits through the slot of the rebound bracket. The Hilux of some years have a bit smaller slot, then you have to grind it a bit bigger. Easiest way to do it is with a 'dremel'.
2. Two holes on the centreline of the plate needs to be used. There are two pitches, 80 mm and on the other side 95 mm. Choose always the pitch that will bring the counter sunk bolts as close as possible to the chassis. Two of the four small metal plates will not be used.
3. The counter sunk bolt close to the side of the top plate has to be at the wheel side.
4. Stick the strap through the slot of the rebound bracket. Hold the top plate on the correct position against the rebound bracket.





## Toyota Hilux 4WD L.HI.L4.C.M

5. Tighten equally the nuts on top of the small metal plate. Take care the top plate is installed flat against the rebound bracket in a horizontal position. Do not over tighten.
6. After the installation of the top plate, the sticker with the kit code and number must be placed on the inside on top of the top plate



### 5.2 Installation of lower plate

1. Loosen the U-bolts and remove the bump stop ( pictures 1 and 2 )
2. Position the lower plate on top of the leaf springs with the longer part pointing inwards. ( picture 4 )
3. Tighten the U-bolts. With a torque of 123Nm

### 5.3 Installation of the air spring

1. Attach the hose to the air spring (see also 5.5)
2. Bring the air lines true the big hole of the lower plate, black is left end blue is right
3. Place the bolts with disc washers. Leave some clearance to allow aligning the air spring.
4. Always check if the air bellows won't touch any obstacle

Toyota Hilux 4WD  
L.HI.L4.C.M

5.4 Fitting of Inflator Console

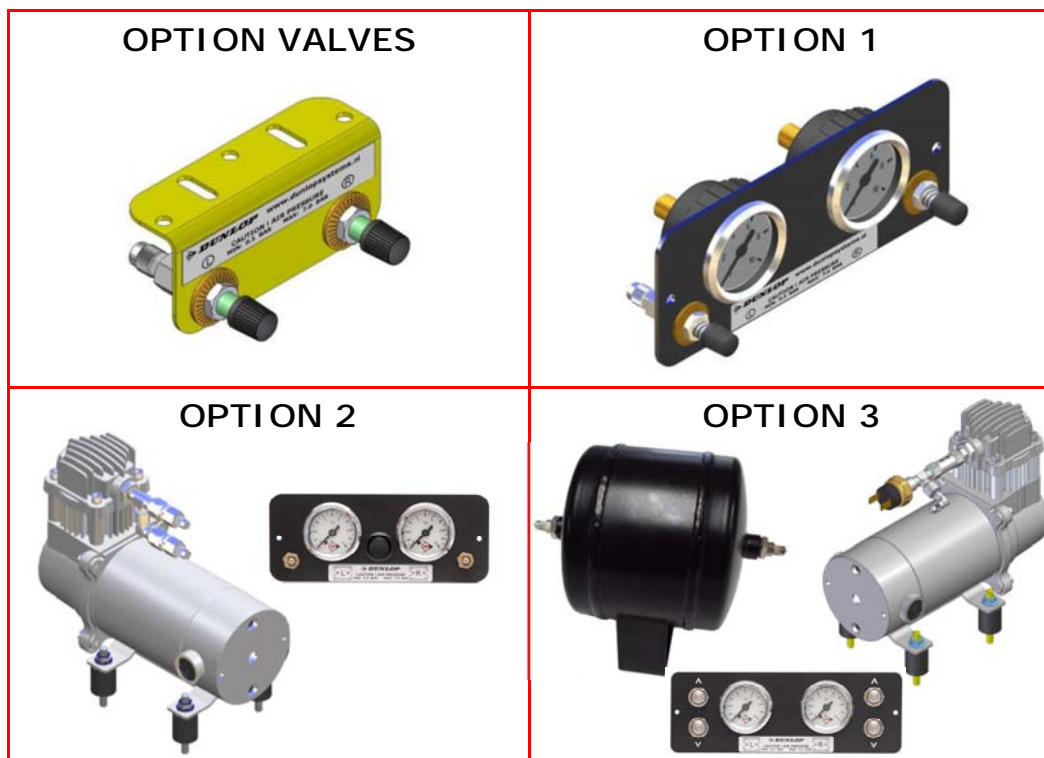

Your kit is supplied with one of the inflator options shown above...

- **OPTION VALVES** : Two valves and a small bracket
- **OPTION 1** : Two valves in a console with two independent 10-bar pressure gauges
- **OPTION 2** : Two valves in a console with two independent 10-bar pressure gauges and a rocker on/off switch to operate the electric motor driven air compressor
- **OPTION 3** : Four valves (two for raising the vehicle ('UP') and two for lowering the vehicle ('DOWN')) in a console with two independent 10-bar pressure gauges. A pressure switch operates the electric motor driven air compressor to keep the air reservoir of 2.2-litre at pressure.

## Toyota Hilux 4WD L.HI.L4.C.M

Mount the console in a position of your choice whereby it is firmly fixed, has some protection from the environment (particularly important for the console with gauges) and is easily accessible. Suggested possible locations include...

### 'Standard' Console...

- on the rear bumper
- at the rear beside the license plate
- on the chassis next to a rear wheel
- in a service shutter (motorhomes)
- beside the fuel cap

### 'Option 1', 'Option 2' or 'Option 3' Console...

- in the vehicle cabin, within reach and sight of the driver
- Beside, under the driver seat
- in the wall of a cupboard (motorhomes)
- in a service shutter (motorhomes)

### 'Comfort' Packages

The 'Option 2' and 'Option 3' panels, as shown above, are each part of a *Comfort Package* that is supplied with a compressor (and also an air reservoir in the case of the 'Option 3' panel) for ease of spring inflation and ride height setting. For further information please ask your dealer.

The photograph below shows all of the parts of Comfort Package 'Option 2'...



Comfort Package 'Option 2'

Toyota Hilux 4WD  
L.HI.L4.C.M

5.5 Tube Connection and Disconnection, Cutting and Routing

Connection and Disconnection

Tubes are connected as shown by the diagrams below...

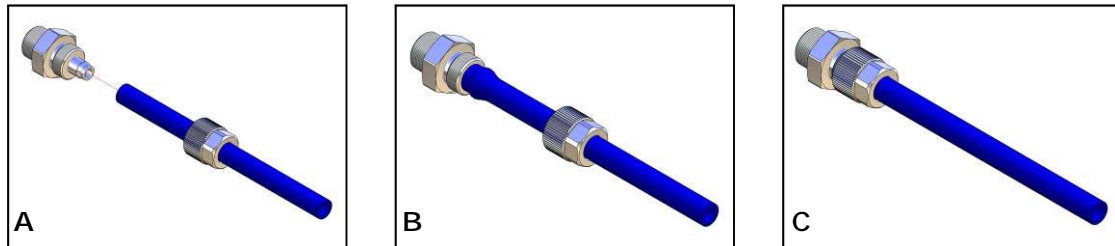

- A. Slide a nut over the end of the tube
- B. Push the tube onto the connector as far as possible
- C. Feed the nut up to the connector, avoid rotating of the air tube, then fully tighten by hand and finally tighten one additional turn using spanners

Cutting

To achieve good sealing and air-tight fitting of tube ends to their connecting parts, it is very important to cut tubing cleanly and squarely. A dedicated guillotine action tubing cutter is recommended, or a craft knife if such a tool is not available. Do not use electrician's side cutters.



A dedicated tubing cutter -  
**Recommended**



Electrician's Side Cutters  
**NOT Recommended**

## Toyota Hilux 4WD L.HI.L4.C.M

### Routing

Study the underside of the vehicle and decide how to route each branch of the air circuit...

- To minimise the risk of chafing, avoid running tubing over metal edges as much as possible
- Avoid close proximity to heat sources such as the exhaust assembly
- Choose a route that provides as much protection as possible from dirt, debris and any solid objects that may impact the underside of the vehicle

It is recommended that tubes are guided alongside brake lines or hand brake cables as much as possible.



Use cable ties ('tie wraps') to secure tubing to the chassis, taking care not to over-tighten them.

### 5.6 Spring Inflation

Once installation of the air assist kit is complete, inflate the springs via the inflator console taking careful note of the following...



#### Maximum and Minimum Pressure

**Maximum Pressure 7.0bar**      **Minimum Pressure 0.5bar**

Do not exceed 7.0bar (101psi), which is the recommended maximum charge pressure for the air springs.

The springs may be deflated if the vehicle is to be stored for a lengthy period without use, but a pressure of at least 0.5bar (7.25psi) should be maintained at all times in order to avoid possible compression damage to the springs.

It is wise to hand over the vehicle 24 hours after the installation is done. Just to assure the customer will leave with an airtight system.

## Toyota Hilux 4WD L.HI.L4.C.M

### 5.7 Spring Alignment

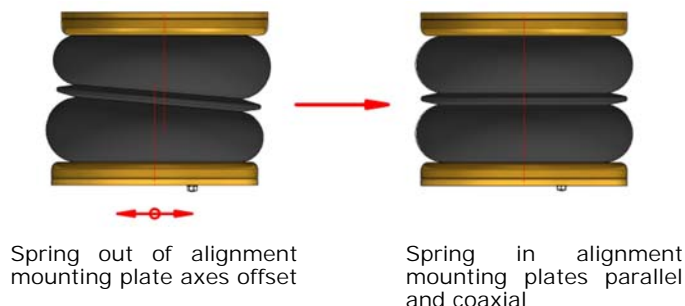

#### CAUTION!

Before fully tightening the bolts that secure the air spring to the upper and lower brackets, set the vehicle at ride height (spring height approximately 14cm) and ensure that the springs are correctly aligned.

### 5.8 Maintenance

Following installation, it is recommended that all metal parts are coated with a protective substance such as body wax. Following each winter, check the wax coating and re-coat as necessary.

The system does not require very much maintenance other than...

- ◆ to maintain air pressure in the springs. Much like a tyre, the system may lose a little air over time.
- ◆ to keep the air springs clean. It is suggested that, when washing the vehicle, the springs are inspected and cleaned as necessary (preferably by spraying). Look in particular for stones or grit trapped between convolutes, as this may damage the spring.

Toyota Hilux 4WD  
L.HI.L4.C.M

5.9 Installation Pictures

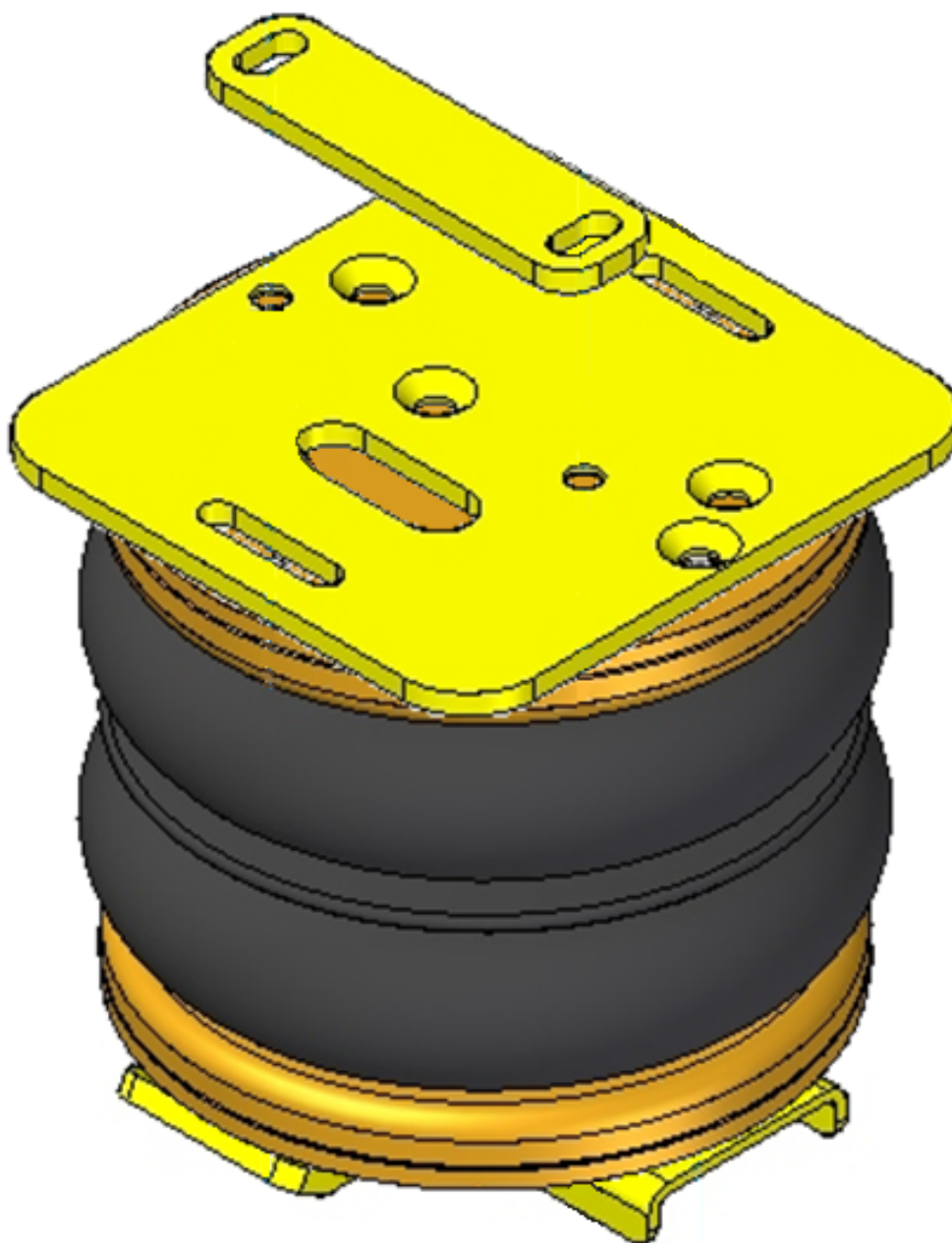

Toyota Hilux 4WD  
L.HI.L4.C.M

1



2



3



4

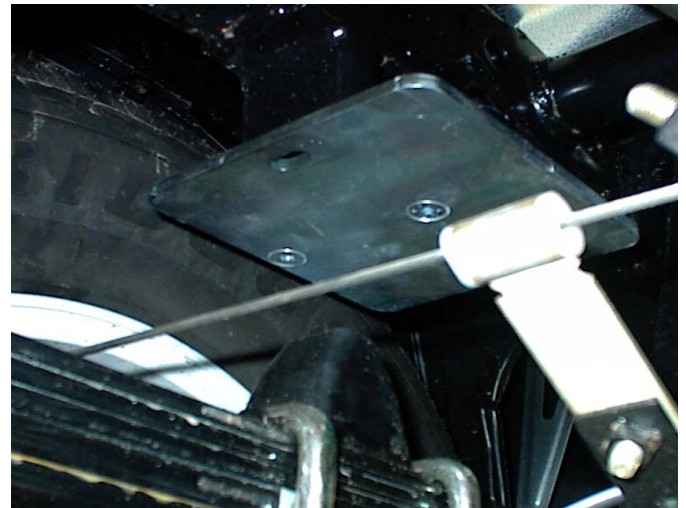

5

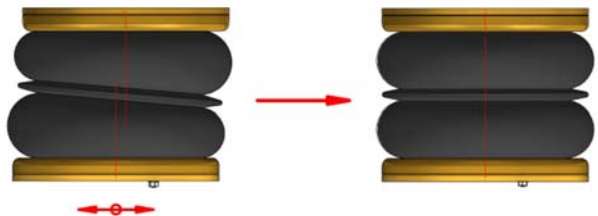
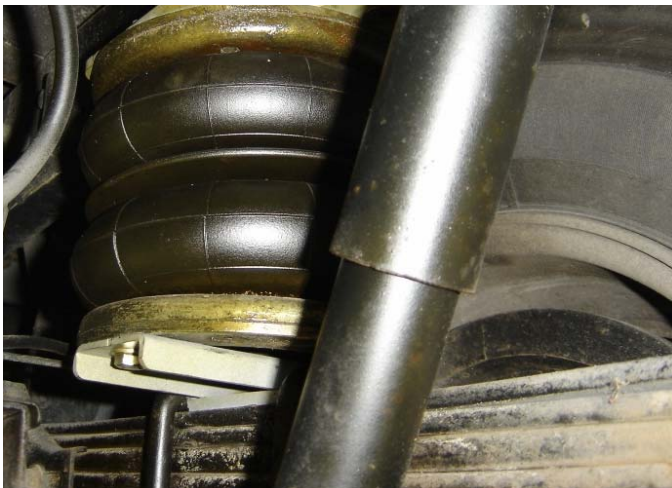

Spring out of alignment  
mounting plate axes offset

Spring in alignment  
mounting plates parallel  
and coaxial



Toyota Hilux 4WD  
**L.HI.L4.C.M**

**5.10 Check List**

Before driving the vehicle following completion of installation of the auxiliary air suspension system, please check...

- ...all bolts tightened to the recommended torque (Page 8)?
- ...air springs set in alignment (Section 5.4)?
- ...enough free space around the air springs to avoid wearing?
- ...all metal parts wax coated (Section 5.5)?
- ...manufacturer's declaration form completed and a copy returned?



A wait of 24 hours is recommended in order to ensure that the vehicle has maintained its stance and that there are no air leaks present.

**6. EPILOGUE**

DSC Nederland hopes that you enjoy the benefits that your *DUNLOP* air suspension system will provide for you. To ensure optimal performance, we advise that you have your system checked frequently by qualified personnel. As recommended in the fitting instructions, it is important to coat all the steel parts with a protective substance such as body wax.

**IMPORTANT : Manufacturer's Declaration Form**

A manufacturer's declaration form is provided with your kit. Following installation of the kit please ensure that this form is completed, signed by a qualified fitter and a copy is returned to DSC Nederland by post, fax or e-mail. Our e-mail address is: [info@dunlopsystems.nl](mailto:info@dunlopsystems.nl)

As a condition of your warranty, modifications to the system may only be carried out by personnel of DSC Nederland.

**Enquiries**

For general enquiries please contact one of our dealers. You can find them on our website.

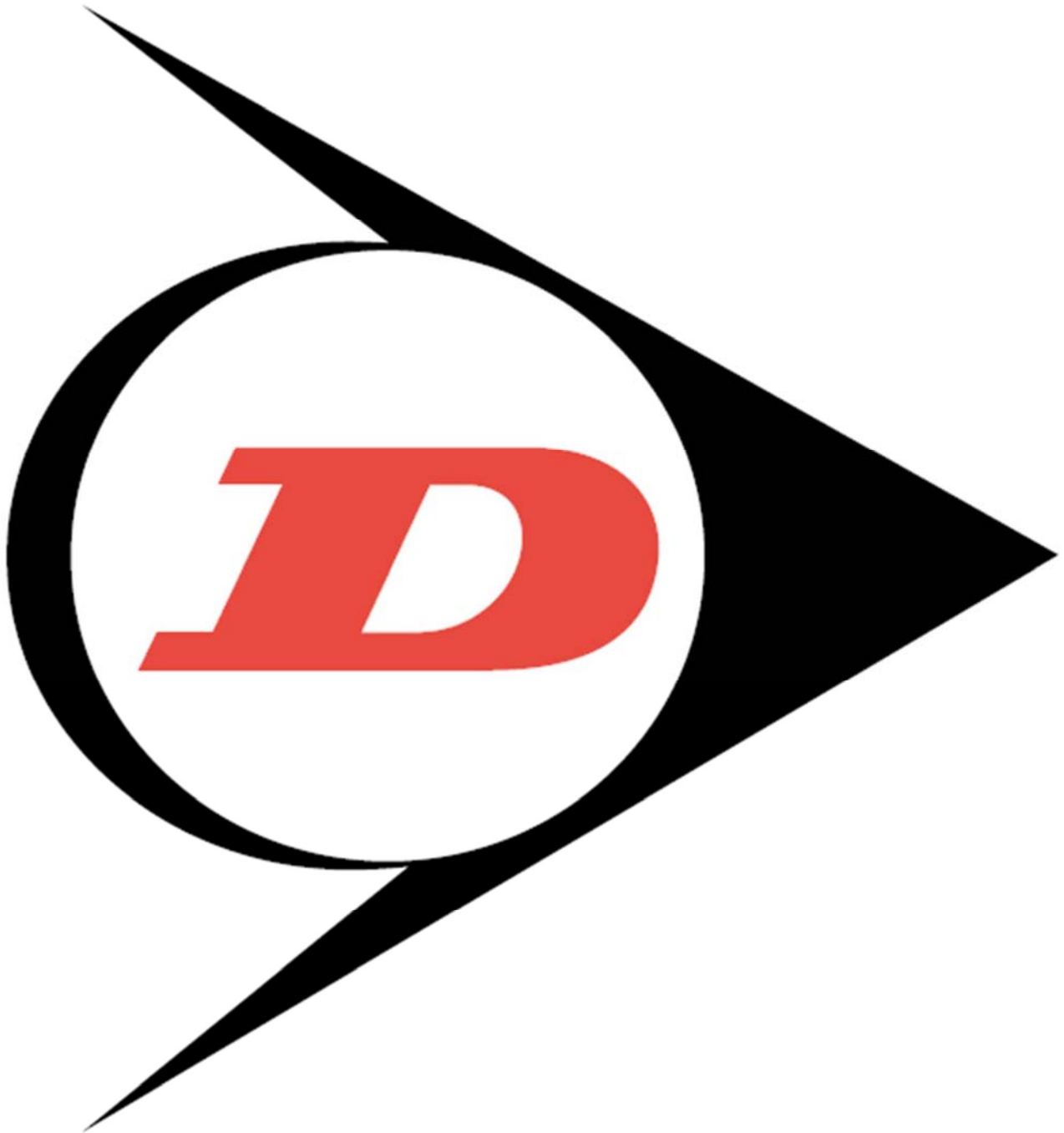

DSC Nederland B.V.  
Het Wegdam 22  
7496 CA Hengevelde  
Nederland  
Tel. : +31 (0)547 333065  
Fax. : +31 (0)547 333068  
e-mail: [info@dunlopsystems.nl](mailto:info@dunlopsystems.nl)

[www.dunlopsystems.nl](http://www.dunlopsystems.nl)