

Installation Manual

L.DOBLO.C.M

Fiat Doblo (2001 - 2010)

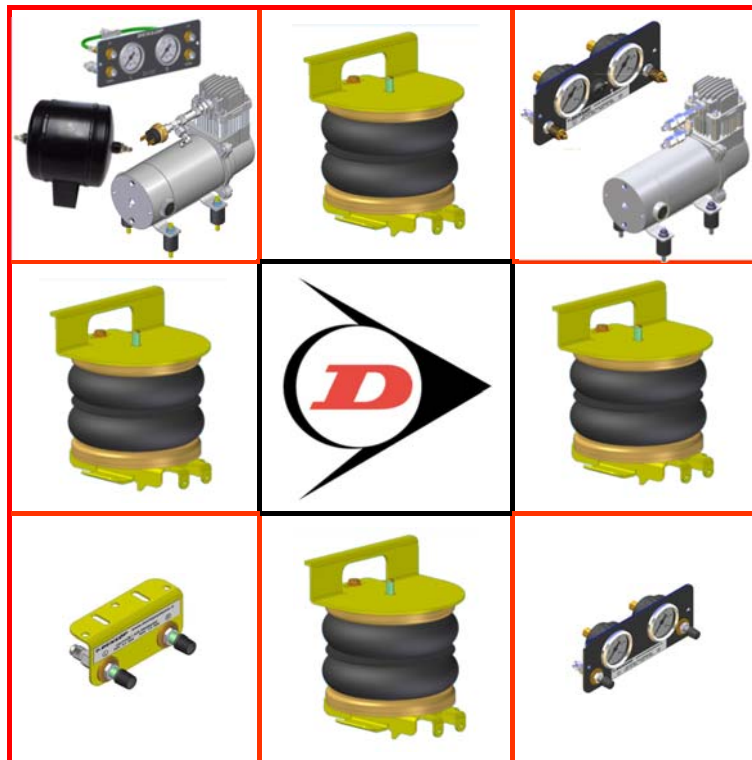



Fiat Doblo

L.DOBLO.C.M

CONTENTS

1. FOREWORD	3
2. INTRODUCTION	4
3. VERY IMPORTANT NOTES.....	5
4. OVERVIEW	6
5. INSTRUCTIONS FOR INSTALLATION	7
5.1. Recommended Tightening Torque.....	7
5.2. Preparation	7
5.3. Attachment of Lower Bracket to Bellow	8
5.4. Bump Stop Removal and fitting of Upper Bracket.....	8
5.5. Fitting of Lower Bracket and Bellow	8
5.6. Fitting of Inflator Console.....	10
5.7. Tube Connection and Disconnection, Cutting and Routing	12
5.8. Spring Inflation.....	13
5.9. Spring Alignment	14
5.10. Maintenance.....	14
5.11. Installation Drawings	15
5.12. Check list.....	17
6. EPILOGUE	17

DSC Nederland B.V.
Het Wegdam 22
7496 CA Hengevelde
Nederland
Tel. : +31 (0)547 333065
Fax. : +31 (0)547 333068
e-mail: info@dunlopsystems.nl
Website: www.dunlopsystems.nl

© 2017, DSC Nederland B.V.



Fiat Doblo

L.DOBLO.C.M

1. FOREWORD

This manual provides instructions for the installation of an auxiliary air suspension kit, developed specifically for the Fiat Doblo (2001 - 2010). To ensure correct installation of the kit, it is strongly recommend that these instructions are read thoroughly before commencing any installation work. Installation should only be carried out by a suitably qualified mechanic or specialist installation facility. DSC Nederland will not accept any responsibility for faults or defects arising from incorrect installation, which automatically renders the guarantee invalid.

IMPORTANT : Manufacturer's Declaration Form

A manufacturer's declaration form is provided with your kit. Following installation of the kit please ensure that this form is completed, signed by a qualified fitter and a copy is returned to DSC Nederland by post, fax or e-mail. Our e-mail address is: info@dunlopsystems.nl



Fiat Doblo

L.DOBLO.C.M

2. INTRODUCTION

Thank you for choosing an auxiliary air suspension kit from the range offered by *DSC Nederland*. Auxiliary air suspension is fitted in tandem with the standard steel springs of the vehicle suspension, and provides enhancements in terms of both the stability of the vehicle and the comfort of the passengers...

Vehicle Levelling

Simply by varying the air pressure in the springs, the vehicle can be levelled both front-to-rear and side-to-side. Keeping the vehicle level optimises stability, ensures correct headlamp beam distribution and reduces tyre wear arising from uneven distribution of weight.

Straight Line Stability

Straight line stability is greatly increased at higher speeds, and when subjected to buffeting from cross-winds or large overtaking vehicles.

Reduced Body Roll

Body roll when cornering or negotiating roundabouts is significantly reduced.

Fatigue Reduction and Wear Compensation

Suspension fatigue is reduced, so helping to prevent leaf springs from sagging under repeated or constant loading. Any sagging already present can be compensated-for. This is a particular benefit for motorhomes, which are always fully laden.

Ride Comfort

Air springs help to absorb shock loads from uneven road surfaces, therefore general ride quality is much improved.



Fiat Doblo

L.DOBLO.C.M

3. VERY IMPORTANT NOTES



Gross Vehicle Weight (GVW)

Air assist kits are not in themselves designed to increase the gross vehicle weight (GVW) rating of a vehicle. They do not legally allow for carriage of a load greater than the carrying capacity stated on the data plate of the vehicle.

Do not exceed the maximum load specified by the vehicle manufacturer...

- ◆ to avoid compromising passenger safety
- ◆ to prevent possible damage to the vehicle
- ◆ for legal reasons

Vehicle Uprating

Despite the above words of caution, it is possible to upgrade the weight rating of your vehicle. This must be carried-out by a specialist supplier that will...

- ◆ carry out any necessary modifications in addition to fitting the air assist kit
- ◆ complete documentation as necessary to inform the Vehicle and Operator Services Agency (VOSA) – a mandatory requirement
- ◆ supply and fit a new weight plate to replace the original plate supplied with the vehicle

This process applies to United Kingdom registered vehicles. The process in other countries may be different.

Safety Guidance Note

The following very useful guidance note is available for free download from the *Health and Safety Executive (HSE)*...

PM85, July 2007 *Safe recovery (and repair) of buses and coaches fitted with air suspension*

The uniform resource locator (URL) for this document is...

<http://www.hse.gov.uk/PUBNS/pm85.pdf>

Fiat Doblo

L.DOBLO.C.M

4. OVERVIEW

Number	Part Number	Description	Quantity
1	20.06.00.1.01	TOP PLATE	2
2	10.05.00.1.04	LOWER BRACKET	2
3	OP.LB.170-2.CPL	AIR BELLOW 170/2	2
4	DIN933 M8 x 16	HEXAGONE BOLT	6
5	M8	DISC SPRING WASHER	6
6	DIN127 M10	SPRING WASHER	2
7	DIN933 M10 x 1.25 X 30	HEXAGONE BOLT	2

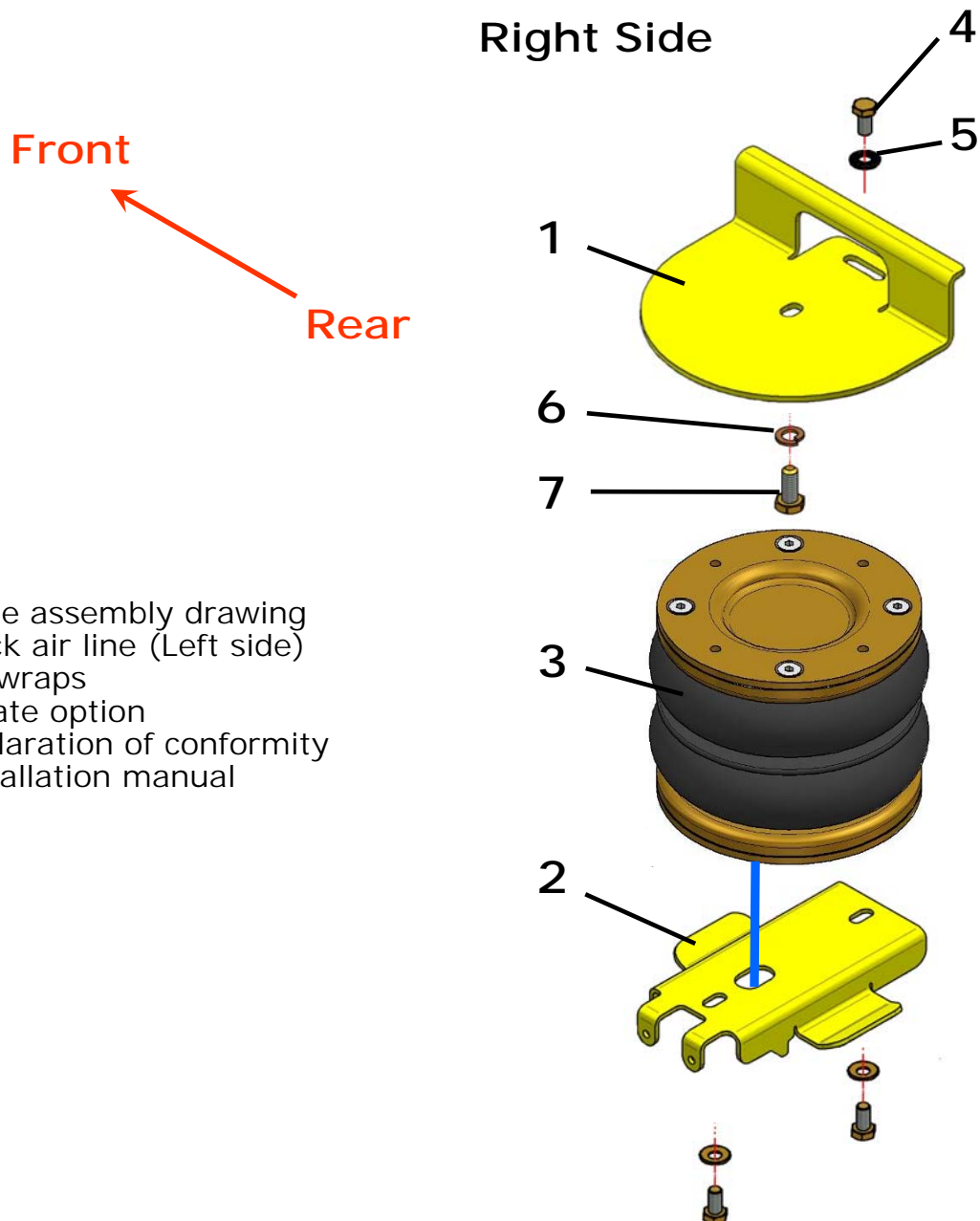

- Not in the assembly drawing
- Black air line (Left side)
 - Tie wraps
 - Inflate option
 - Declaration of conformity
 - Installation manual



Fiat Doblo

L.DOBLO.C.M

5. INSTRUCTIONS FOR INSTALLATION



Preparation and Precaution

Before beginning installation, ensure that you have sufficient clearance between the axle and the chassis. Use a jack if necessary. Install at one side of the vehicle at a time.



Pay attention to your safety at all times during installation - always use axle stands to support the vehicle!



Position the axle stands under the chassis (not the rear axle) with a clearance of approximately 25 cm between the chassis and the rear axle.

5.1 Recommended Tightening Torque

During fitting of the air suspension system, it is recommended that nuts and bolts are tightened in accordance with the following table...

METRIC TORQUE CHART IN N.m		
SIZE	CLASS 8.8	CLASS 10.9
M6 x 1	9.9	14.0
M8 x 1.25	24.0	34.0
M10 x 1.5	48.0	67.0
M12 x 1.75	83.0	117.0
M16 x 2	200.0	285.0

- When both the bolt and nut are made from steel use either class 8.8 or 10.9
- For all other materials, tightening torque is left to the discretion of a person skilled in the art

The following instructions make reference to the diagrams on pages 14 to 19 inclusive.

5.2 Preparation

- Secure the front wheels, use wheel chocks on both sides of both front wheels.
- Take the ground terminal from the battery when work to electricity is involved.
- Lift the rear of the vehicle till there is working space of approximately 25 cm between bump stop and rear axle.





Fiat Doblo

L.DOBLO.C.M

5.3 Attachment of Lower Bracket to Bellow

Attach the lower bracket to the bellow as indicated by the diagram of Section 4. Do not fully tighten at this stage because...

- (i) otherwise it may prove difficult or impossible to slot the U-bolts between the lower plate of the bellow and the lower bracket (in step 4 of section 5.4).
- (ii) the bellow may require alignment once inflated (see Section 5.9, Figure 19)

5.4 Bump Stop Removal and fitting of Upper Bracket

- i. Unscrew and remove the bump stop — Figures 1 and 2. The hole vacated by removal of the bump stop will be used for attachment of the upper bracket.
- ii. Attach the upper bracket to the chassis using the M10 x 1.25 x 30mm bolt and M10 spring washer — Figures 3 and 4.

5.5 Fitting of Lower Bracket and Bellow

- i. See Section 5.7 - "*Tube Connection and Disconnection, Cutting and Routing*" : Connect a tube to the bellow by pushing the tube onto the air inlet port on the underside of the spring and then hand-rotating the tube by one screw turn. Use black tubing for the left-hand bellow and blue for the right-hand bellow.
- ii. Remove the U-bolts that attach a clamping plate to the leaf spring and then remove and discard the plate itself — Figures 5 and 6
- iii. See figures 7, 8 and 9 : Place the bellow over the leaf spring paying attention to orientation—see arrows on Figures 7 and 8. Also observe the routing of the air pipe from the side of the bracket—Figure 9.
- iv. Place the U-bolts over the lower bracket and through their original mounting holes. Secure the bolts using four flat washers, four spring washers and four nuts—Figures 7 and 8. Tighten all four nuts to torque 110Nm (81lbf.ft).
- v. Fully secure the lower bracket to the bellow by tightening the two M8 x 16 bolts. Note that access to these bolts is now a little restricted but is still possible.
- vi. Attach the top plate of the bellow to the upper bracket using two M8 x 16 bolts and two M8 spring washers—Figures 10 and 11. Do not fully tighten at this stage because the bellow may require alignment once inflated (see Section 5.9, Figure 19)

Fiat Doblo

L.DOBLO.C.M

5.6 Fitting of Inflator Console

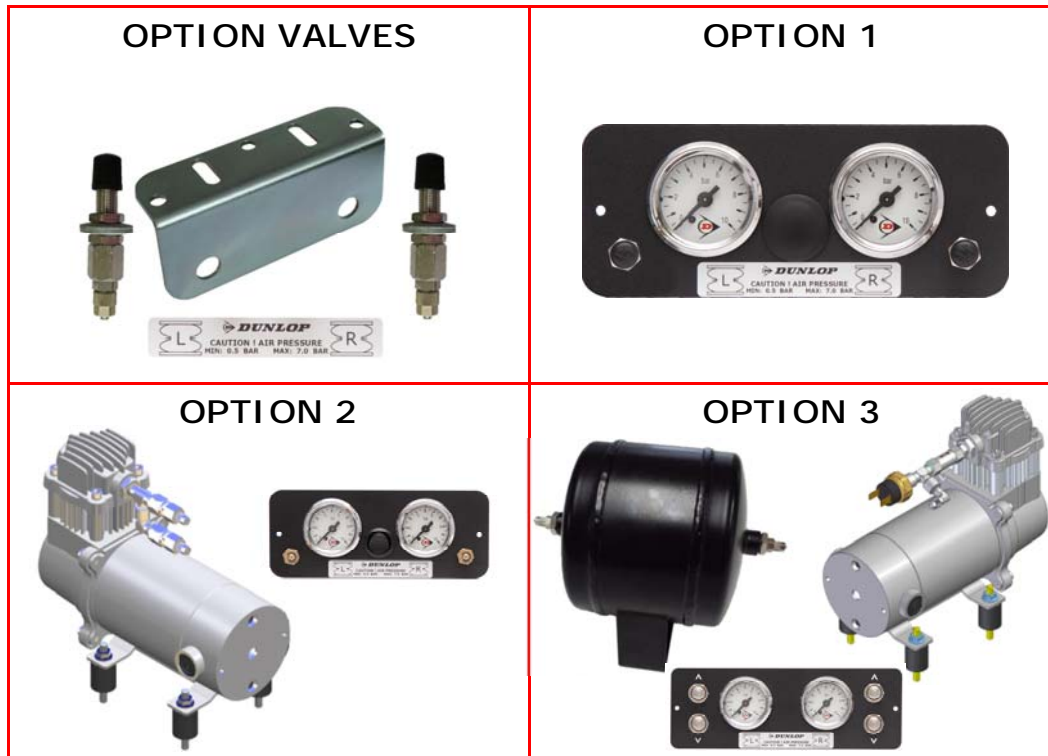

Your kit is supplied with one of the inflator options shown above...

- **OPTION VALVES** : Two valves and a small bracket
- **OPTION 1** : Two valves in a console with two independent 10-bar pressure gauges
- **OPTION 2** : Two valves in a console with two independent 10-bar pressure gauges and a rocker on/off switch to operate the electric motor driven air compressor
- **OPTION 3** : Four valves (two for raising the vehicle ('UP') and two for lowering the vehicle ('DOWN')) in a console with two independent 10-bar pressure gauges. A pressure switch operates the electric motor driven air compressor to keep the air reservoir of 1.9-litre at pressure.



A special panel is available for **OPTION 1** and **OPTION 2**

Fiat Doblo

L.DOBLO.C.M

Mount the console in a position of your choice whereby it is firmly fixed, has some protection from the environment (particularly important for the console with gauges) and is easily accessible. Suggested possible locations include...

'Standard' Console...

- on the rear bumper
- at the rear beside the license plate
- on the chassis next to a rear wheel
- in a service shutter (motorhomes)
- beside the fuel cap

'Option 1', 'Option 2' or 'Option 3' Console...

- in the vehicle cabin, within reach and sight of the driver
- Beside, under the driver seat
- in the wall of a cupboard (motorhomes)
- in a service shutter (motorhomes)

'Comfort' Packages

The 'Option 2' and 'Option 3' panels, as shown above, are each part of a *Comfort Package* that is supplied with a compressor (and also an air reservoir in the case of the 'Option 3' panel) for ease of spring inflation and ride height setting. For further information please ask your dealer.

The picture below shows all of the parts of Comfort Package 'Option 2'...



Comfort Package 'Option 2'

5.7 Tube Connection and Disconnection, Cutting and Routing

Connection and Disconnection

Tubes are connected as shown by the diagrams below...

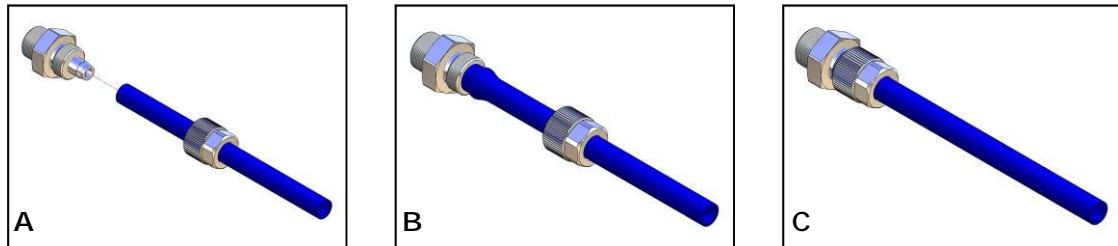

- A. Slide a nut over the end of the tube
- B. Push the tube onto the connector as far as possible
- C. Feed the nut up to the connector, fully tighten by hand and finally tighten one additional turn using spanners

Cutting

To achieve good sealing and air-tight fitting of tube ends to their connecting parts, it is very important to cut tubing cleanly and squarely. A dedicated guillotine action tubing cutter is recommended, or a craft knife if such a tool is not available. Do not use electrician's side cutters.



A dedicated tubing cutter -
Recommended



Electrician's Side Cutters
NOT Recommended



Fiat Doblo

L.DOBLO.C.M

Routing

Study the underside of the vehicle and decide how to route each branch of the air circuit...

- To minimise the risk of chafing, avoid running tubing over metal edges as much as possible
- Avoid close proximity to heat sources such as the exhaust assembly
- Choose a route that provides as much protection as possible from dirt, debris and any solid objects that may impact the underside of the vehicle

It is recommended that tubes are guided alongside brake lines as much as possible.



Use cable ties ('tie wraps') to secure tubing to the chassis, taking care not to over-tighten them.

5.8 Spring Inflation

Once installation of the air assist kit is complete, inflate the springs via the inflator console taking careful note of the following...



Maximum and Minimum Pressure

Maximum Pressure 7.0bar **Minimum Pressure 0.5bar**

Do not exceed 7.0bar (101psi), which is the recommended maximum charge pressure for the air springs.

The springs may be deflated if the vehicle is to be stored for a lengthy period without use, but a pressure of at least 0.5bar (7.25psi) should be maintained at all times in order to avoid possible compression damage to the springs.



Fiat Doblo

L.DOBLO.C.M

5.10 Spring Alignment

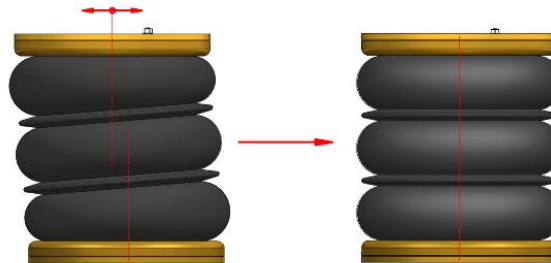

Spring out of alignment
mounting plate axes
offset

Spring in alignment
mounting plates parallel
and coaxial



CAUTION!

Before fully tightening the bolts that secure the air spring to the upper and lower brackets, set the vehicle at ride height (spring height approximately 18.5cm) and ensure that the springs are correctly aligned.

5.11 Maintenance

Following installation, it is recommended that all metal parts are coated with a protective substance such as body wax.

The system does not require very much maintenance other than...

- ♦ to maintain air pressure in the springs. Much like a tyre, the system may lose a little air over time.
- ♦ to keep the air bellows clean. It is suggested that, when washing the vehicle, the bellows are inspected and cleaned as necessary (preferable by spraying). Look in particular for stones or grit trapped between convolutes, as this may damage the bellow.
- ♦ Check before and after the winter period the wax coating. Re-wax when necessarily



Fiat Doblo
L.DOBLO.C.M

5.11 Installation Drawings

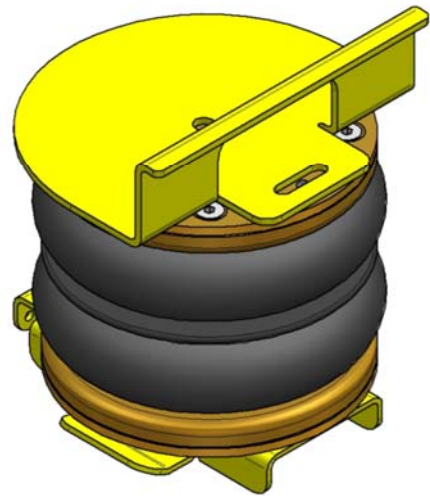
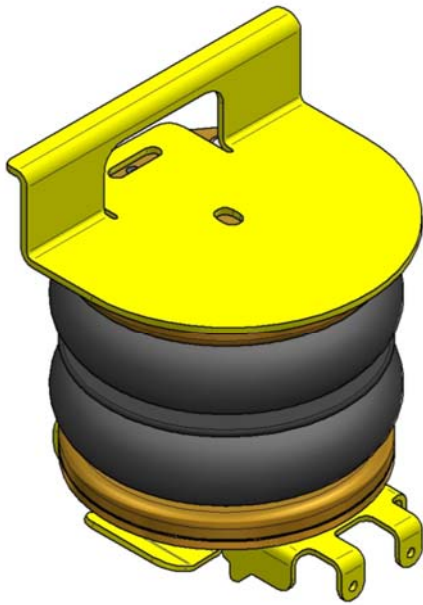

Fiat Doblo
L.DOBLO.C.M

1

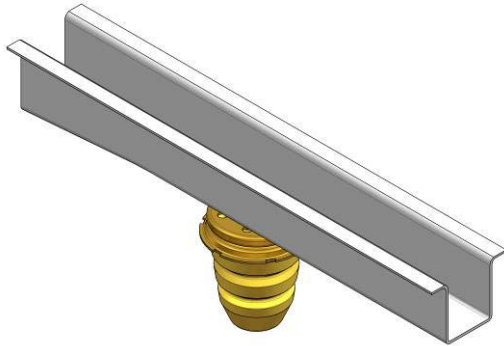

2

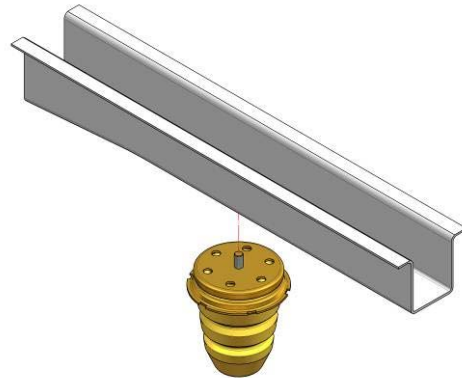

3

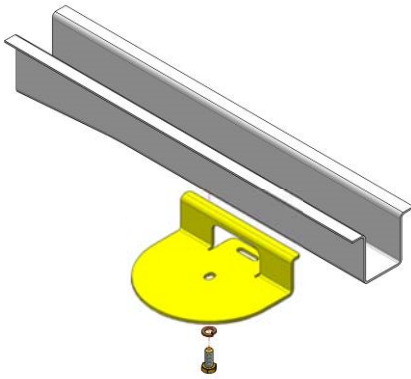

4

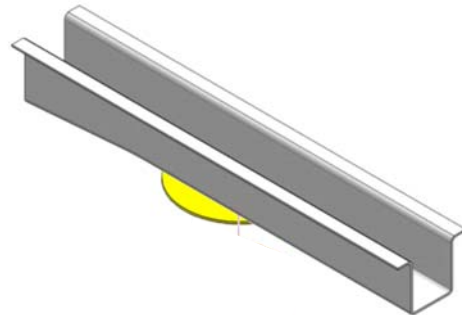

5

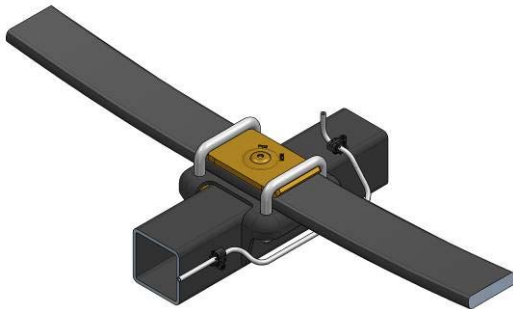

6

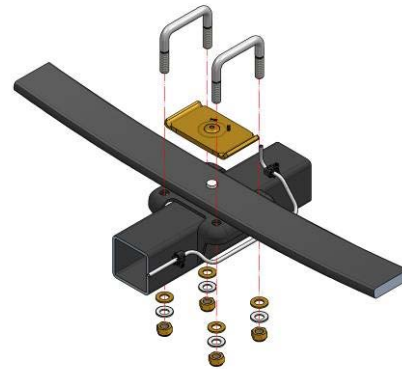

7

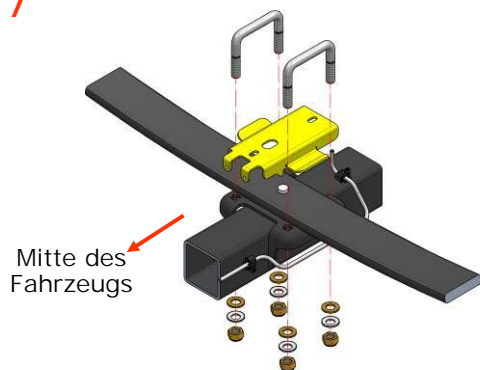

8

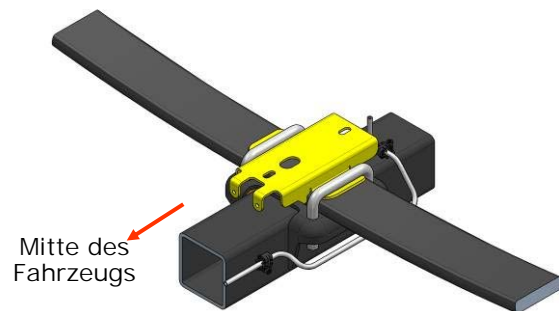

Fiat Doblo
L.DOBLO.C.M

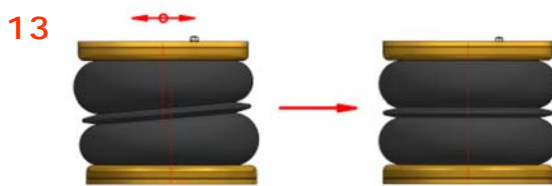
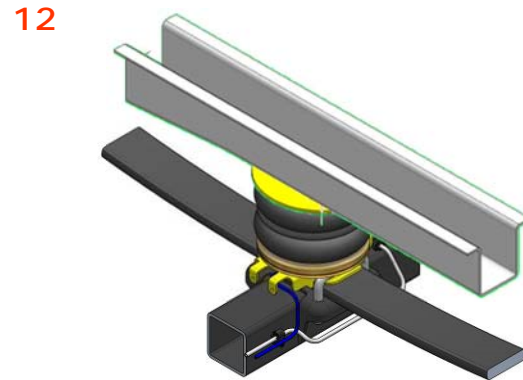
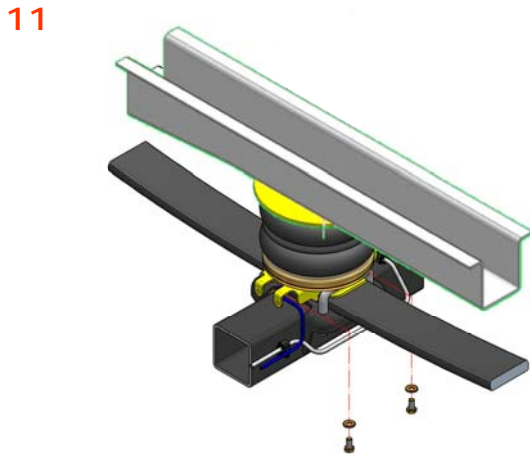
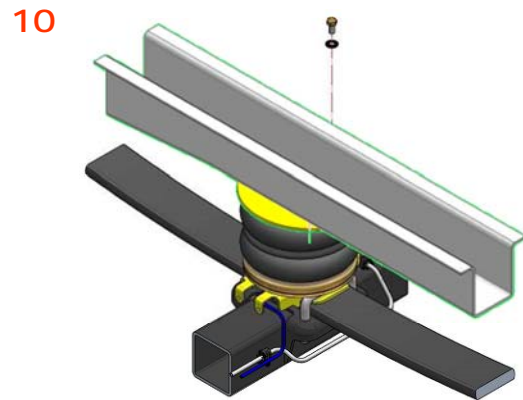
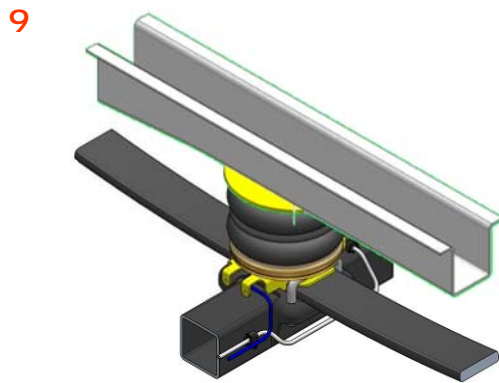

Spring out of alignment—
—mounting plate axes
offset

Spring in alignment—
—mounting plates parallel
and coaxial



CAUTION!

Before fully tightening the bolts that secure the air spring to the upper and lower brackets, set the vehicle at ride height (spring height approximately 18.5cm) and ensure that the springs are correctly aligned.



Fiat Doblo

L.DOBLO.C.M

5.12 Check List

Before driving the vehicle following completion of installation of the auxiliary air suspension system, please check...

- ...all bolts tightened to the recommended torque (Page 7)?
- ...air springs set in alignment (Section 5.10)?
- ...enough free space around the air springs to avoid wearing?
- ...all metal parts wax coated (Section 5.11)?
- ...manufacturer's declaration form completed and a copy returned?



A wait of 24 hours is recommended in order to ensure that the vehicle has maintained its stance and that there are no air leaks present.

6. EPILOGUE

DSC Nederland hopes that you enjoy the benefits that your *DUNLOP* air suspension system will provide for you. To ensure optimal performance, we advise that you have your system checked frequently by qualified personnel. As recommended in the fitting instructions, it is important to coat all the steel parts with a protective substance such as body wax.

IMPORTANT : Manufacturer's Declaration Form

A manufacturer's declaration form is provided with your kit. Following installation of the kit please ensure that this form is completed, signed by a qualified fitter and a copy is returned to DSC Nederland by post, fax or e-mail. Our e-mail address is: info@dunlopsystems.nl

As a condition of your warranty, modifications to the system may only be carried out by personnel of DSC Nederland.

Enquiries

For general enquiries please contact one of our dealers. You can find them on our website.

www.dunlopsystems.nl

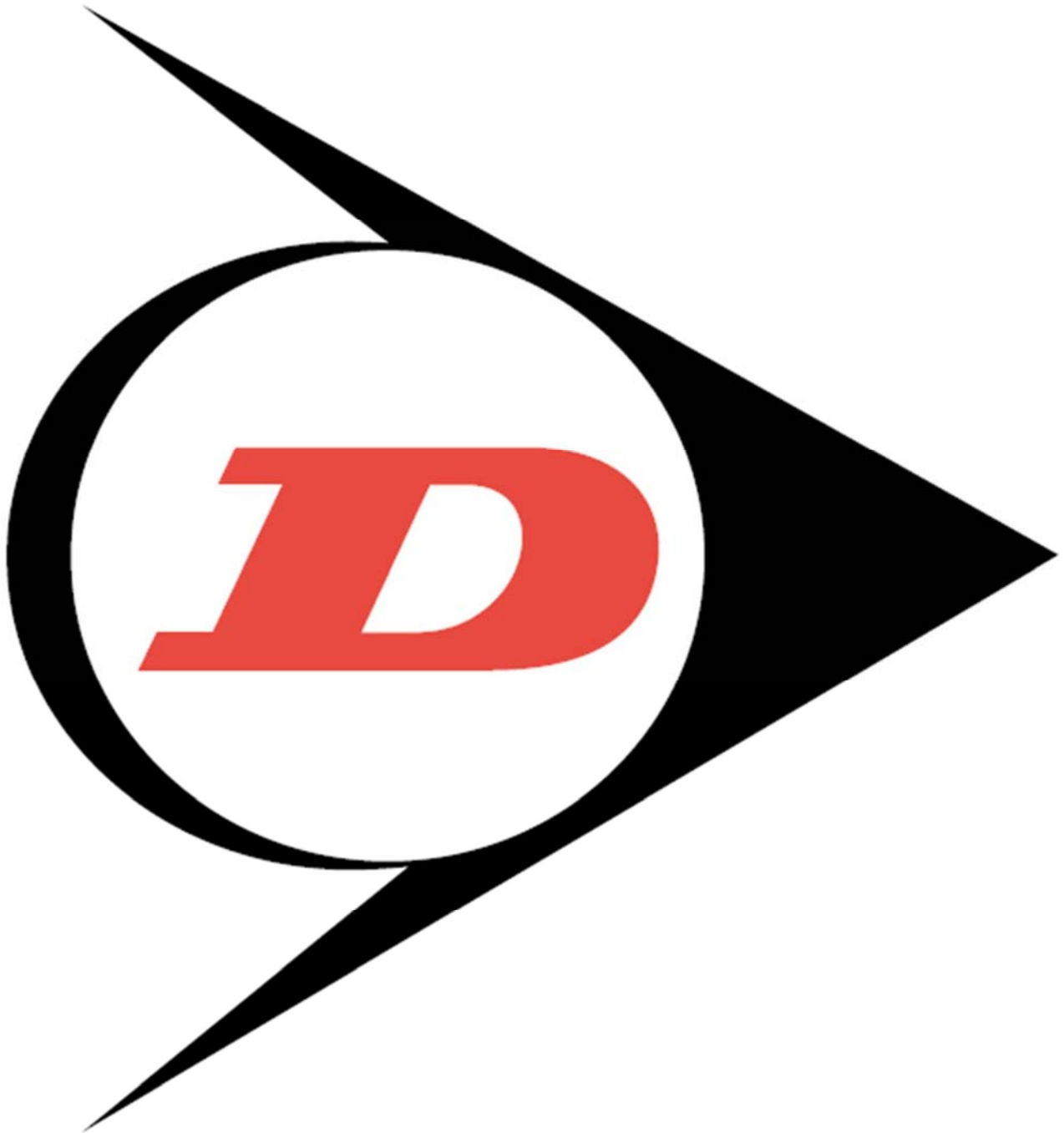

DSC Nederland B.V.
Het Wegdam 22
7496 CA Hengevelde
Nederland
Tel. : +31 (0)547 333065
Fax. : +31 (0)547 333068
e-mail: info@dunlopsystems.nl

www.dunlopsystems.nl